



Peanut





Contents

3. Introduction ST range
4. ST1 / ST1 Vision
5. ST2
6. ST3
7. ST4
8. ST-X4
9. ST-X5
10. ST-X8
11. ST-X Wide
12. ST Technical Specification
13. ST Colour Options
14. ST Burnished door
15. The Peanut Range
16. Peanut Range Introduction
17. Peanut Technical Specification
18. Peanut 3
19. Peanut 5
20. Bignut 5
21. Peanut 8
22. Peanut Marine

ST Range Introduction

Saltfire's 'ST' range is a selection of precision engineered high efficiency Ultra-Clean-burning stoves. The results of thousands of hours research and development at our dedicated solid fuel research centre in Dorset. Saltfire engineers have been hard at work reducing smoke emissions these past few years, 'ST' stoves also feature extremely low CO, NOx, particle and Hydro-Carbon emissions. This advanced Clean-Burn technology is a huge leap forward for wood burners.

Designed for maximum efficiency and extremely clean-burning, all 'ST' models are certified with DEFRA for use in Smoke Control Areas in the UK and are all EcoDesign 2022 compliant.

The ST-X hybrid range incorporate the benefits of both heavy cast iron components and thick steel outer body which is up to 10mm thick. Available in three kW sizes and now also all available in our new taller and slimline options. They have an amazing clean burn control and airwash for Ultra-Clean glass - We challenge any other stove brands to produce cleaner glass.

All are simple to operate and easy to maintain. All incorporate an advanced 'After-Burner' system for Super-Cleanburning and amazing flame pattern. Hot Air-Wash for clean glass and views of the fire as standard. We keep all models in stock at our factory warehouse in Dorset and can supply in a range of colours.

ST1/ST1 VISION

Designed with simple, easy to operate user friendly controls. Constructed using a triple-layer body, there is a precision engineered welded outer and inner steel body (air gap between layers) with thermo-refractory fire brick inner linings.

Designed with a large viewing window for amazing views of the fire. The flame pattern with the advanced “after-burner” system is quite unique.

The air-wash clean glass system is particularly impressive.

The ST1 Vision is a larger door/window version of the original ST1 model and are both dedicated wood burners only.

Key Features

Nominal Heat Output	5 kW
High Efficiency	✓ 78.7%
Wood burning	✓
Eco Design 2022 Ready	✓
Optimum Heat Output Range	1 to 5kW
Advanced Airwash	✓
Maximum Log Length	12”(300mm)
Ultra Clean Burn	✓
DEFRA Exempt for Smokeless Zones	✓
Large View Ceramic Glass	✓
Other colours available	✓
Flue Outlet Top	5”(125mm)
Room Vent Not Normally Needed	✓
Suitable for Use on 12mm Hearth	✓
Fire brick lined	✓
5 Year Guarantee	✓

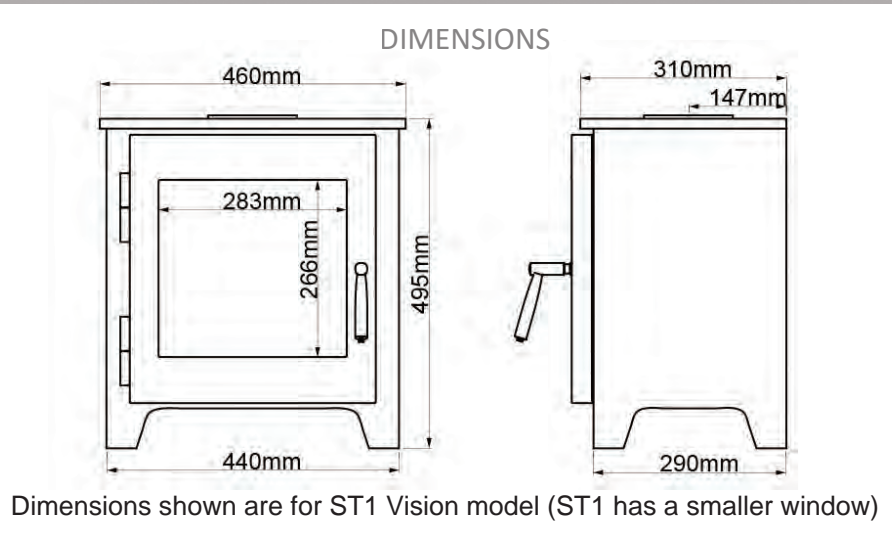

ST2

The Saltfire ST2 is a great looking modern design ultra-clean-burning wood and multi-fuel stove.

Designed with simple, easy to operate user friendly controls. Constructed using a triple-layer convection system, there is a precision engineered welded outer and inner steel body with thermo-refractory fire brick inner linings.

The ST2 is a multi-fuel stove able to burn wood logs and smokeless coal - the coal ashes will fall through the grate and into the ash pan which easily lifts out when full.

There is an air-wash system to help keep the glass clearer.

Key Features

Nominal Heat Output	5kW
High Efficiency	✓ 79.2%
Multifuel Ready	✓
Eco Design 2022 Ready	✓
Optimum Heat Output Range	1 to 5kW
Advanced Airwash	✓
Maximum Log Length	12"(300mm)
Ultra Clean Burn	✓
DEFRA Exempt for Smokeless Zones	✓
Large View Ceramic Glass	✓
Other colours available	✓
Flue Outlet Top	5"(125mm)
Room Vent Not Normally Needed	✓
Suitable for Use on 12mm Hearth	✓
Fire brick lined	✓
5 Year Guarantee	✓



DIMENSIONS

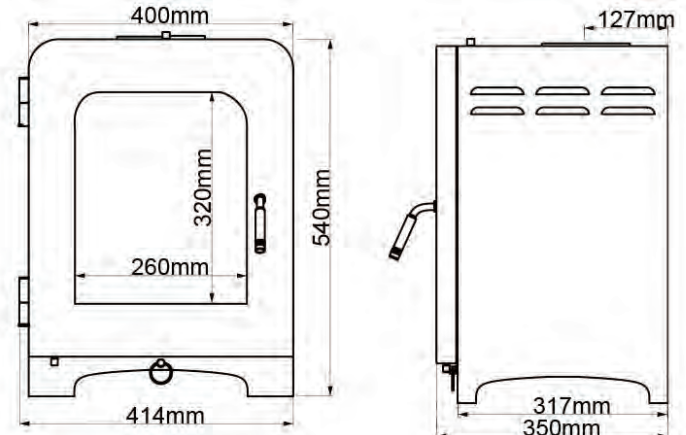

ST3

Designed with simple, easy to operate user friendly controls. Constructed using a triple-layer body, there is a precision engineered welded outer and inner steel body (air gap between layers) with thermo-refractory fire brick inner linings.

Designed with a large viewing window for amazing views of the fire. The flame pattern with the advanced "after-burner" system is quite unique.

The air-wash clean glass system is particularly impressive.

The ST3 is a dedicated wood burner only

Key Features

Nominal Heat Output	7.3kW
High Efficiency	✓ 76.3%
Wood burning	✓
Eco Design 2022 Ready	✓
Optimum Heat Output Range	2 to 7.5kW
Advanced Airwash	✓
Maximum Log Length	15"(360mm)
Ultra Clean Burn	✓
DEFRA Exempt for Smokeless Zones	✓
Large View Ceramic Glass	✓
Other colours available	✓
Flue Outlet Top	5"(125mm)
Fire brick lined	✓
Suitable for Use on 12mm Hearth	✓
5 Year Guarantee	✓



DIMENSIONS

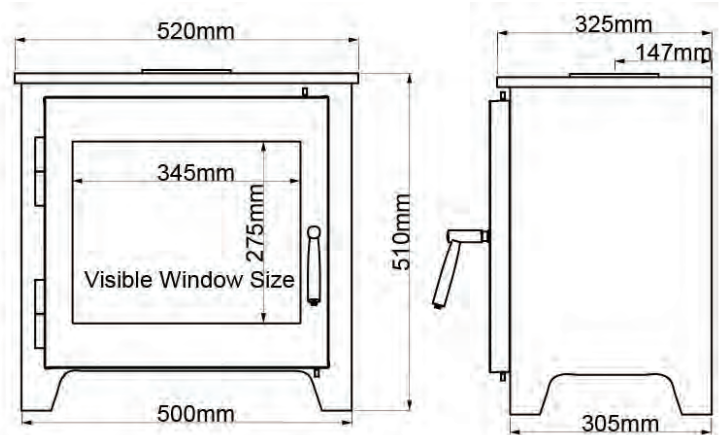

ST4

The Saltfire ST4 is the larger version of the popular ST2 - and is a great looking modern design ultra-clean-burning wood and multi-fuel stove.

Designed with simple, easy to operate user friendly controls. Constructed using a triple-layer convection system, there is a precision engineered welded outer and inner steel body with thermo-refractory fire brick inner linings.

The ST4 is a multi-fuel stove able to burn wood logs and smokeless coal - the coal ashes will fall through the grate and into the ash pan which easily lifts out when full.

There is an air-wash system to help keep the glass clearer.

The ST4 has a removable baffle plate to allow cleaning access to the flue.

Key Features

Nominal Heat Output	7.2 kW
High Efficiency	✓ 76.7%
Multifuel Ready	✓
Eco Design 2022 Ready	✓
Optimum Heat Output Range	2 to 7.5kW
Advanced Airwash	✓
Maximum Log Length	15"(360mm)
Ultra Clean Burn	✓
DEFRA Exempt for Smokeless Zones	✓
Large View Ceramic Glass	✓
Other colours available	✓
Flue Outlet Top	5"(125mm)
Fire brick lined	✓
Need Constructional Hearth	✓
5 Year Guarantee	✓



DIMENSIONS

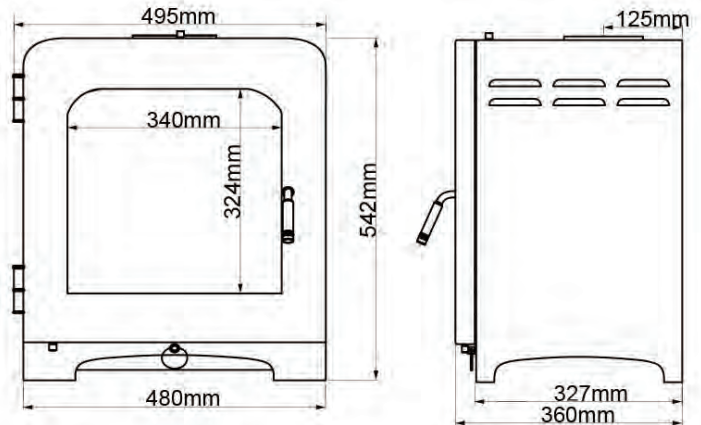



Key Features

Nominal Heat Output	4.2 kW
High Efficiency	✓ 76.1%
Multifuel Ready	✓
Eco Design 2022 Ready	✓
Optimum Heat Output Range	1 to 5kW
Advanced Airwash	✓
Maximum Log Length	10"(270mm)
Ultra Clean Burn	✓
DEFRA Exempt for Smokeless Zones	✓
Large View Ceramic Glass	✓
Other colours available	✓
Flue Outlet Top or Rear	5"(125mm)
Room Vent Not Normally Needed	✓
Fire brick lined	✓
Suitable for a 12mm Hearth	✓
5 Year Guarantee	✓

ST-X4

Available in short and tall options

Constructed from a precision-welded thick steel body with cast iron door and thermo-refractory fire brick inner linings.

Many times cleaner than the required standard for "DEFRA" exemption, it can legally be used anywhere in the UK including the strictest of smoke control zones.

Designed with simple, easy to operate user friendly controls, has a large viewing window for amazing views of the fire. The flame pattern with the advanced "after-burner" system is quite unique.

The ST-X4 is a multi-fuel stove able to efficiently burn wood logs or smokeless coal - the coal ashes will fall through the grate and into the ash pan which easily lifts out when full.

There is an air-wash system to help keep the glass clearer.

SHORT DIMENSIONS

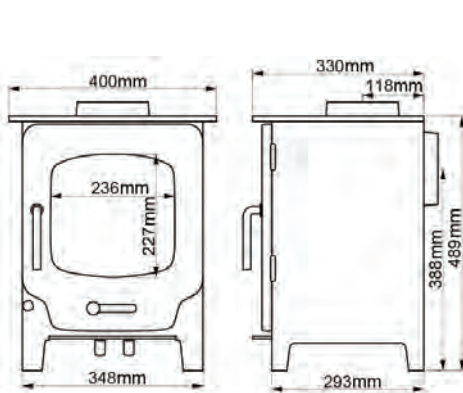

TALL DIMENSIONS

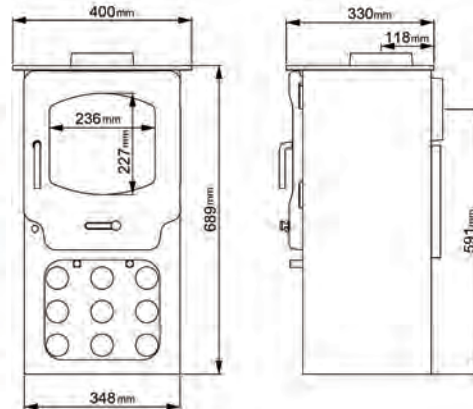



Key Features

Nominal Heat Output	5.0 kW
High Efficiency	✓ 81.8%
Multifuel Ready	✓
Eco Design 2022 Ready	✓
Optimum Heat Output Range	2 to 8kW
Advanced Airwash	✓
Maximum Log Length	12"(320mm)
Ultra Clean Burn	✓
DEFRA Exempt for Smokeless Zones	✓
Large View Ceramic Glass	✓
Other colours available	✓
Flue Outlet Top or Rear	5"(125mm)
Room Vent Not Normally Needed	✓
Suitable for Use on 12mm Hearth	✓
Fire brick lined	✓
5 Year Guarantee	✓

ST-X5

Available in short and tall options

The ST-X5 has a particularly large firebox for a 5kW model allowing a greater range of heat output and for larger logs to be burned.

Constructed from a precision-welded thick steel body with cast iron door and thermo-refractory fire brick inner linings. Many times cleaner than the required standard for "DEFRA" exemption, it can legally be used anywhere in the UK including the strictest of smoke control zones.

Designed with simple, easy to operate user friendly controls, has a large viewing window for amazing views of the fire. The flame pattern with the advanced "after-burner" system is quite unique.

The ST-X5 is a multi-fuel stove able to efficiently burn wood logs or smokeless coal - the coal ashes will fall through the grate and into the ash pan which easily lifts out when full.

SHORT DIMENSIONS

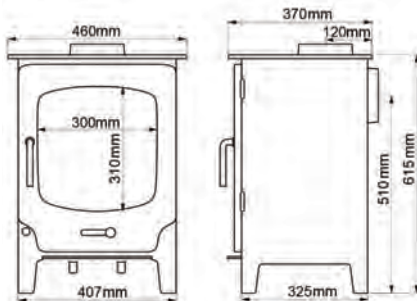

TALL DIMENSIONS

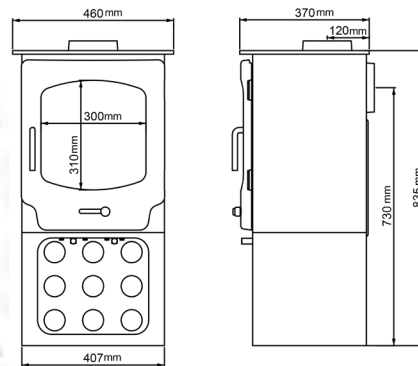



Key Features

Nominal Heat Output	8 kW
High Efficiency	✓ 80.5%
Multifuel Ready	✓
Eco Design 2022 Ready	✓
Optimum Heat Output Range	3 to 10kW
Advanced Airwash	✓
Maximum Log Length	14"(360mm)
Ultra Clean Burn	✓
DEFRA Exempt for Smokeless Zones	✓
Large View Ceramic Glass	✓
Other colours available	✓
Flue Outlet Top or Rear	5"(125mm)
Fire brick lined	✓
Suitable for Use on 12mm Hearth	✓
5 Year Guarantee	✓

ST-X8

Available in short and tall options

The ST-X8 has a large firebox allowing a greater range of heat output and for larger logs to be burned. Constructed from a precision-welded thick steel body with cast iron door and thermo-refractory fire brick inner linings.

Many times cleaner than the required standard for "DEFRA" exemption, it can legally be used anywhere in the UK including the strictest of smoke control zones.

Designed with simple, easy to operate user friendly controls, has a viewing window for amazing views of the fire. The flame pattern with the advanced "after-burner" system is quite unique.

The ST-X8 is a multi-fuel stove able to efficiently burn wood logs or smokeless coal - the coal ashes will fall through the grate and into the ash pan which easily lifts out when full.

SHORT DIMENSIONS

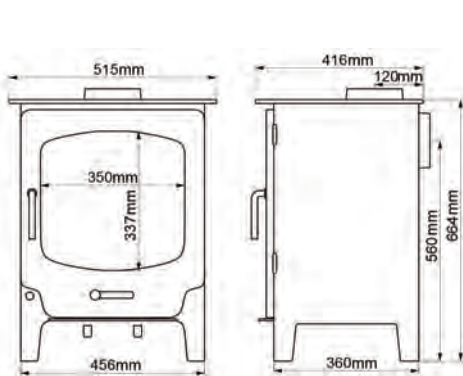

TALL DIMENSIONS

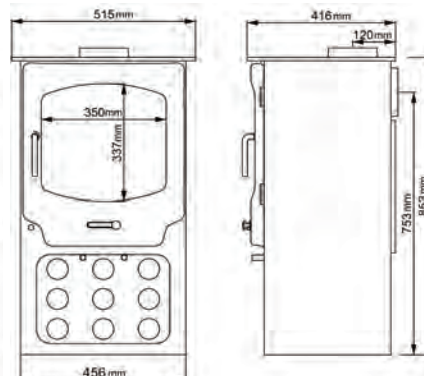



Key Features

Nominal Heat Output	5kW
High Efficiency	✓78.9%
Wood burner with optional multi-fuel kit	✓
Eco Design 2022 Ready	✓
Optimum Heat Output Range	2 to 7kW
Advanced Airwash	✓
Maximum Log Length	16" (400mm)
Ultra Clean Burn	✓
DEFRA Exempt for Smokeless Zones	✓
Large View Ceramic Glass	✓
Other colours available	✓
Flue Outlet Top or Rear	5" (125mm)
Fire brick lined	✓
Suitable for Use on 12mm Hearth	✓
5 Year Guarantee	✓

ST-X Wide

Available in short and tall options

The ST-X Wide is designed to give the widest width and view of the fire whilst keeping the nominal rated output at 5kW.

As one of the widest 5kW stoves available in the UK, there are few rivals in this category. The depth is reduced allowing for easier insertion into shallow fire places or less intrusion into the room when free standing against a wall.

At the same time the wide firebox is retained allowing for longer logs to be used.

SHORT DIMENSIONS

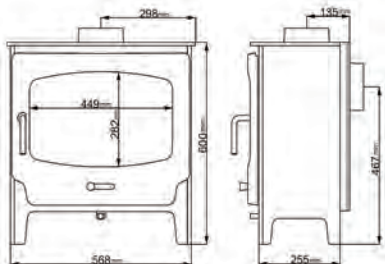

TALL DIMENSIONS

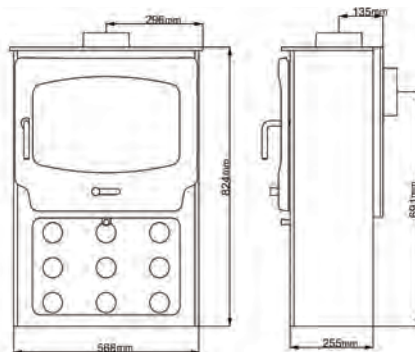

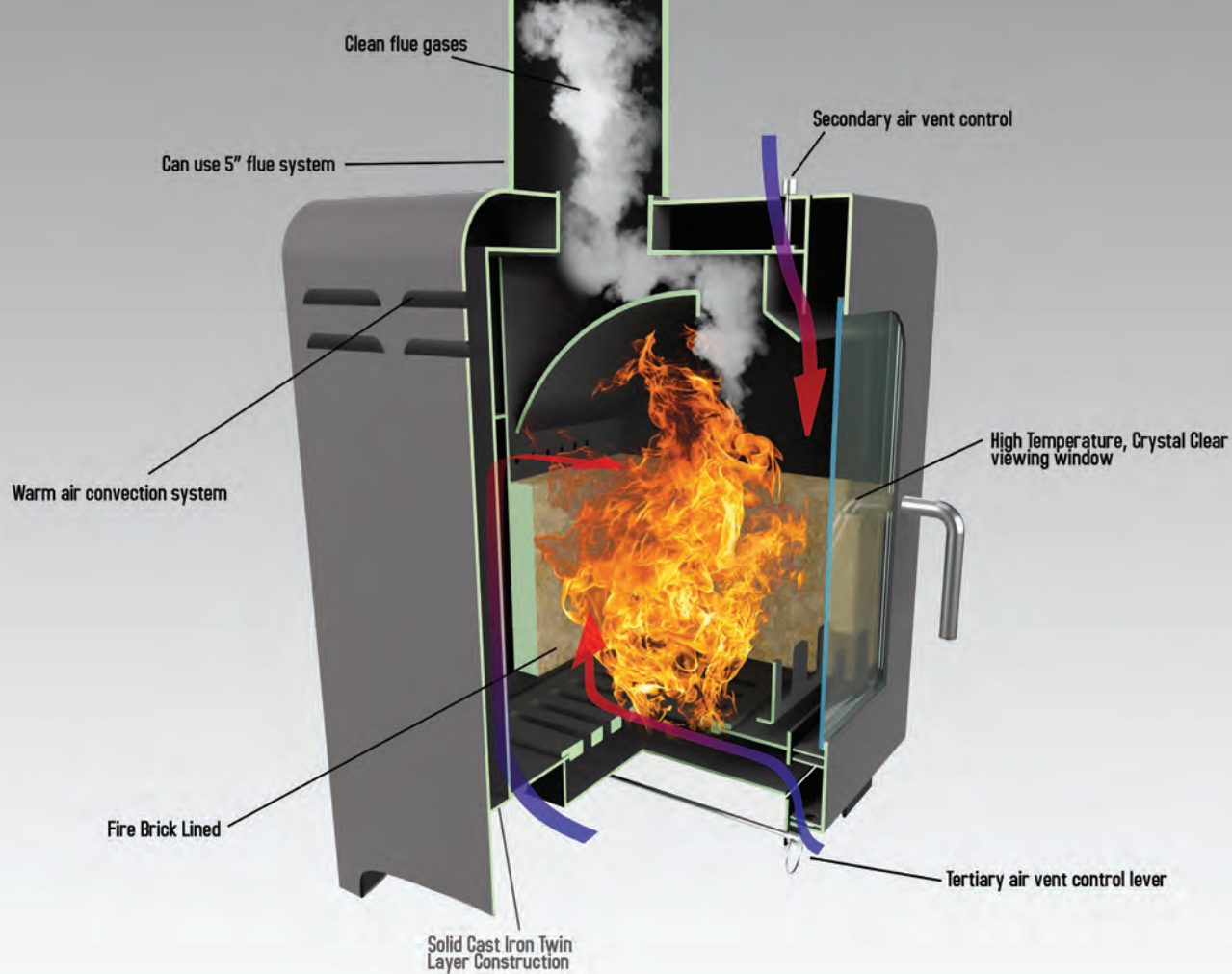

Technical Specification

(ST2 model illustrated)

colours

All models are available in a variety of colours to order.

Simply add colour choice to the end of the model name when ordering with your supplier. -
(If no colour is specified we would supply standard Metallic Black.)

(Colours shown are for representation only and printed brochure may vary slightly from actual colours).



'Metallic Black' - Classic black with subtle metallic fleck adding depth of colour.



'Charcoal Grey' - Quite a dark grey a few shades under Metallic Black.



'Light Grey' - Just as it sounds.



'Mojave Red' - A deepish vibrant red.

Burnished Door

(Available on ST-X Models only)

The cast iron door is finished by hand with various polishing tools and abrasives to give a truly unique bare-metal look, then coated with a clear protective finish - no two are ever the same. Parts of the door over time will then change through many different hues of subtle blues and purples as the stove is heated.



Peanut[®]



Smoke Exempt
Appliance
defra approved
for Smoke Control Areas



Introduction

Wood stove technology and the understanding of wood stove design and engineering has moved on a lot in recent years. Most stoves may look like similar black boxes, but what goes on inside the burn chamber can be very different. The Saltfire Stoves Group is at the forefront of innovations in wood stove combustion and The Peanut range is the result of Saltfire's latest developments in clean-burning, high efficiency stove technology. Created at Saltfire Stoves Group Innovation Centre in Wareham, Dorset, they are designed to be very easy to operate, install and super easy to keep clean and maintain.

With a broad range of outputs on each model, you will have fingertip control to enjoy slower 'lazy flames', or a hotter 'roaring' fire, and anywhere in between – All whilst maintaining high efficiency using fewer logs but giving more heat when you need it. Available in several sizes and rated outputs, each with regular 'short' and 'tall' height options.

The Peanut range features all-cast-iron construction for maximum heat-retention and ultra-clean-burning, by keeping the belly of the fire hot even during 'low & slow' burning. Cast Iron construction also makes for an extremely rugged stove with long life. We know of many cast iron stoves still going strong after 100 years or more, so if you are thinking "how long will my stove last?" – think of it becoming a family heirloom to be handed down to your great grandchildren! Used since the very first invention of wood stoves, Saltfire have chosen to use the reliable qualities of cast iron, brought up to date with the latest innovations in wood combustion technology.

User Friendly

In addition to technical advancements in terms of Clean burn and future proofing legal 2022 Eco-design/ERP standards, Saltfire have made the Peanut range their most user friendly ever. With a powerful boosted stream of air under the fire bed for rapid ignition and refuelling. This is an Eco-design range that consumers will instantly get on with.

Sweep/Installer Friendly

Simple to install and clean/Sweep with easy removable innards.

- **Ecodesign 2022** Ready (future proofed)
- **5 Year Warranty**
- **DEFRA Exempt** / Approved for Smoke Control Areas
- **High Efficiency**, Ultra-Clean-Burning
- All Have **Large Viewing Window**
- Superior Air-wash System for **Crystal-Clear Views** of the Fire
- Full Cast Iron Construction
- External Access to Ashpan for Clean, **Easy Ash Removal**
- Can Use 5" (125mm) Flue System all the way
- Can be used with Top or Rear Flue outlet
- Suitable for use on a **12mm hearth**

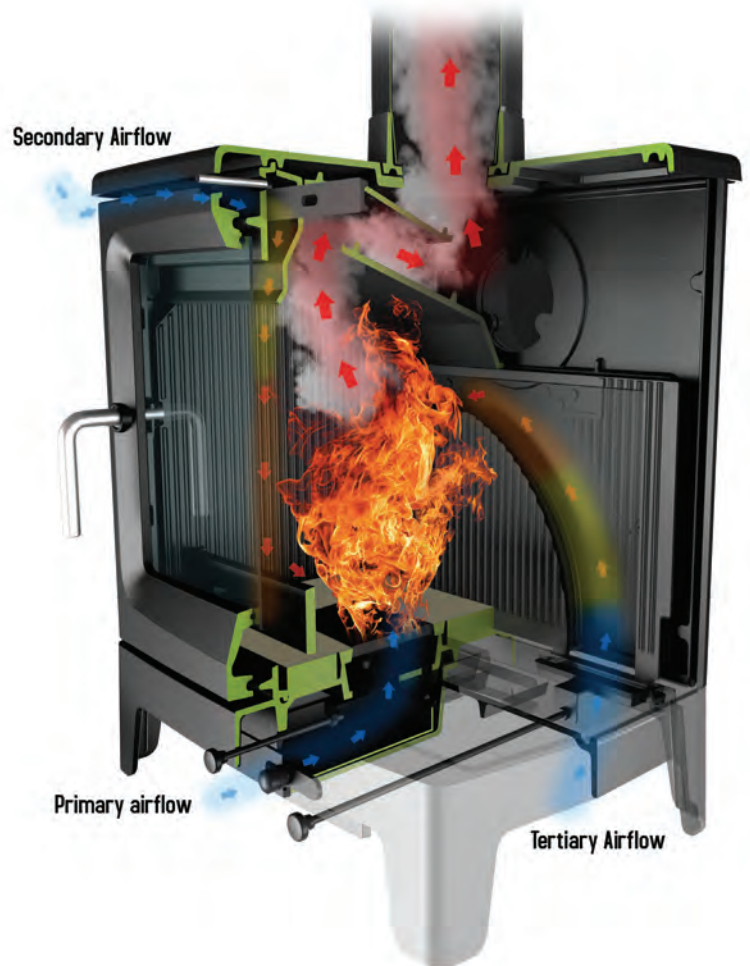



Key Features

Nominal Heat Output	4.7kW
High Efficiency	✓ 82.7%
2022 EcoDesign Read	✓
Ultra Clean Burn	✓
Optimum Heat Output Range	1 to 5 kW
Advanced Airwash	✓
Maximum Log Length	10"/(270mm)
5 Year Guarantee	✓
DEFRA Exempt for Smokeless Zones	✓
Large Viewing window	✓
Black Finish	✓
Flue Outlet Top or Rear	4"/(102mm)
Room Vent Not Normally Needed	✓
Suitable for Use on 12mm Hearth	✓

PEANUT 3

Originally designed as a compact 3kW its actually so efficient it will achieve up to 4.7kW if required. Its viewing window is big for a compact stove! 'Peanut-3' – can fit a very small UK chimney opening of less than 16" wide. – This can make tight installations so much simpler and easier – rarely would any building/ alteration work need to be done even with a small chimney opening.

Ideal for boats and small spaces
(See page 22 for Peanut Marine model)

Optional extras (see website for further details)

- Top Cook Plate
- Marine Hearth
- Fiddle Rail

Available in short and tall options

SHORT DIMENSIONS

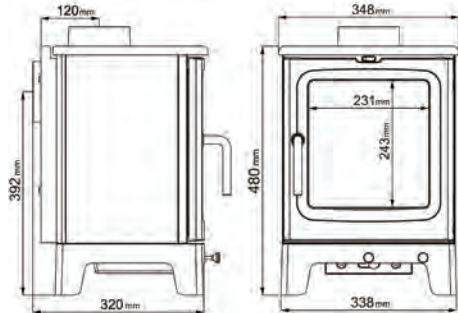

TALL DIMENSIONS

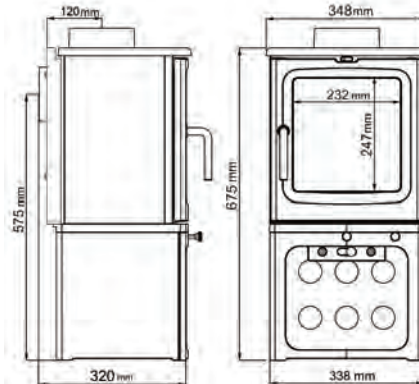



Key Features

Nominal Heat Output	5kW
High Efficiency	✓ 79.9%
2022 EcoDesign Ready	✓
Ultra Clean Burn	✓
Optimum Heat Output Range	2 to 6 kW
Advanced Airwash	✓
Maximum Log Length	11"/(279mm)
5 Year Guarantee	✓
DEFRA Exempt for Smokeless Zones	✓
Large Viewing window	✓
Black Finish	✓
Flue Outlet Top or Rear	5"(125mm)
Room Vent Not Normally Needed	✓
Suitable for Use on 12mm Hearth	✓
Fits standard 16" by 22" Opening	✓

PEANUT 5

Rated at 5kW it can heat a decent sized room easily, with easy variable output between 1.5 and 5kW. Its viewing window is huge for a compact stove! 'Peanut-5' – can fit a 'standard small' UK chimney opening of 16" wide. – This can make some installations so much simpler and easier – rarely would any building/ alteration work need to be done even with a small chimney opening.

If you need something more compact see the Peanut 3

Available in short and tall options

SHORT DIMENSIONS

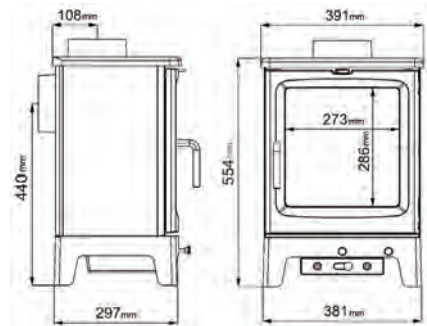

TALL DIMENSIONS

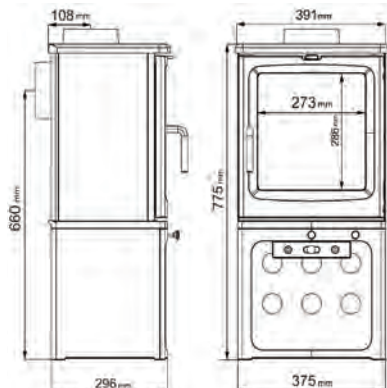

BIGNUT 5

A physically larger version, still rated at 5kW nominal (official output), but with the extra capacity, more physical size and takes longer logs. The Bignut-5 has a variable output range from 3kW up to a maximum of 8kW with easy to operate fingertip controls. A huge viewing window for superb views of the fire. Full cast-iron inner secondary lining plates (fire bricks), for maximum heat retention and are extremely robust.

Available in short and tall options

Key Features

Nominal Heat Output	5kW
High Efficiency	✓ 80.1%
2022 EcoDesign Ready	✓
Ultra Clean Burn	✓
Optimum Heat Output Range	3 to 8kW
Advanced Airwash	✓
Maximum Log Length	13"/(330mm)
5 Year Guarantee	✓
DEFRA Exempt for Smokeless Zones	✓
Large Viewing window	✓
Black Finish	✓
Flue Outlet Top or Rear	5" (125mm)
Room Vent Not Normally Needed	✓
Suitable for Use on 12mm Hearth	✓



SHORT DIMENSIONS

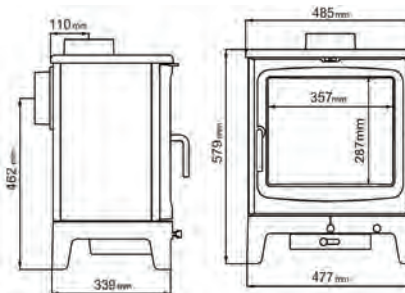

TALL DIMENSIONS

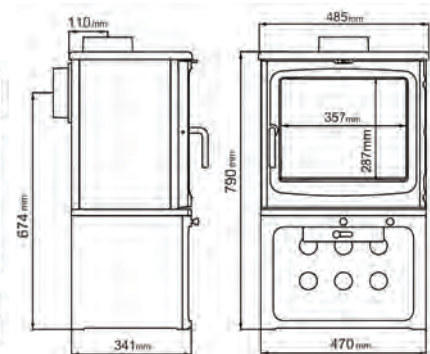

PEANUT 8

A larger capacity version with the same huge viewing window as the Bignut. For those rooms which require something a bit larger or for larger fireplace openings. The Peanut-8 has variable output range from 3kW up to a maximum of 10kW with easy to operate fingertip controls. A huge viewing window for superb views of the fire. Full cast-iron inner lining plates (fire bricks), for maximum heat retention and are extremely robust.

Available in short and tall options

Key Features

Nominal Heat Output	7.9kW
High Efficiency	✓ 77.9%
2022 EcoDesign Ready	✓
Ultra Clean Burn	✓
Optimum Heat Output Range	3 to 9kW
Advanced Airwash	✓
Maximum Log Length	15" (381mm)
5 Year Guarantee	✓
DEFRA Exempt for Smokeless Zones	✓
Large Viewing window	✓
Black Finish	✓
Flue Outlet Top or Rear	5" (125mm)
Suitable for Use on 12mm Hearth	✓



SHORT DIMENSIONS

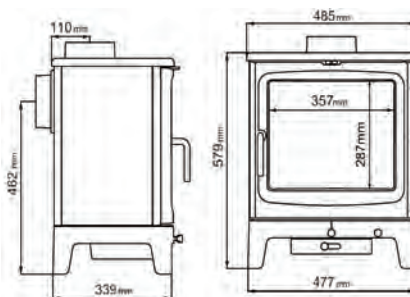

TALL DIMENSIONS

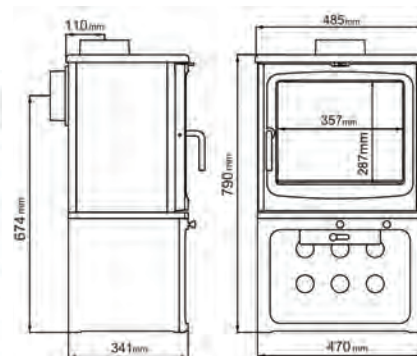

Peanut 3 Marine



Distance to combustibles

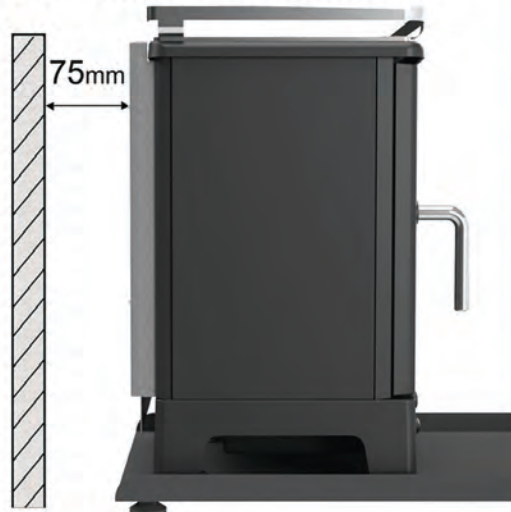

The Saltfire Peanut3. Designed for very small chimney openings and bridging the gap between standard domestic stoves and tiny home/ outdoor space/ glamping specific wood burners. With minimum clearances behind the Peanut 3 as low as 75mm, it is suitable for use in all sorts of combustible material clad buildings. The highly effective double heatshield on the rear comes as standard on the Peanut3. The boat-specific version named 'Peanut Marine', with incorporated cook-top, fiddle rail and it's compact marine hearth, making it the perfect package for boat installations and much easier to comply with BS 8511:2010.



Peanut Marine

Based on the Peanut 3 with incorporated cook-top, fiddle rail and it's compact marine hearth, making it the perfect package for boat installations and much easier to comply with BS 8511:2010.



www.saltfire.co.uk Tel: 01929 555211 Email: sales@saltfire.co.uk